

LOC	DIST	P	F	ZONE	LTR	DESCRIPTION	DATE	APPR
BD	77					REV PER ECN BD4960	6-20-91	CR
						OBSELETE -2, SUPERSEDED -1 PER ECN BD6411	3/31/93	CR
						REV PER EC 0020-1053-95	05 JAN 96	RLT
						REV PER EC 0420-59-96	20 SEP 96	RT
						REV PER EC 0640-435-98	18 MAR 99	RT

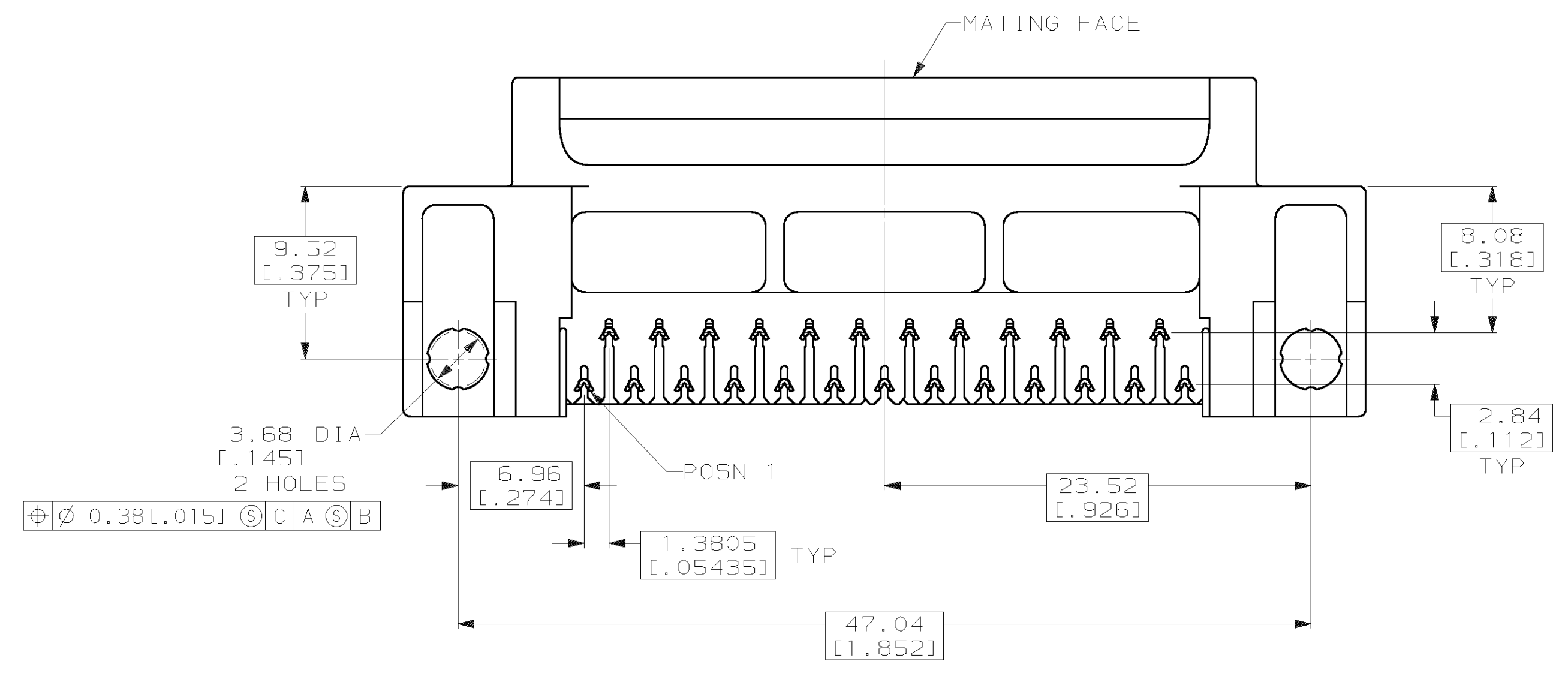
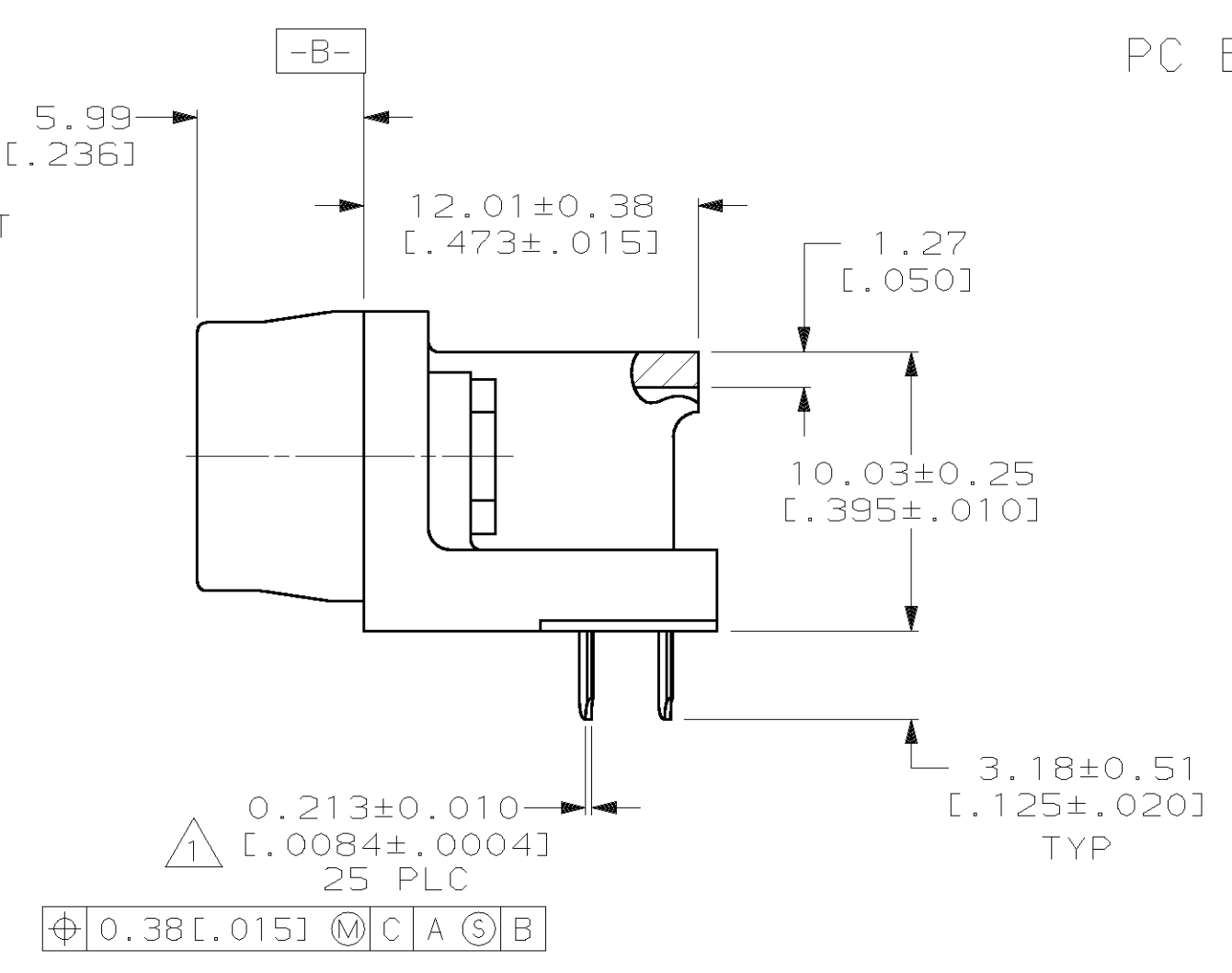
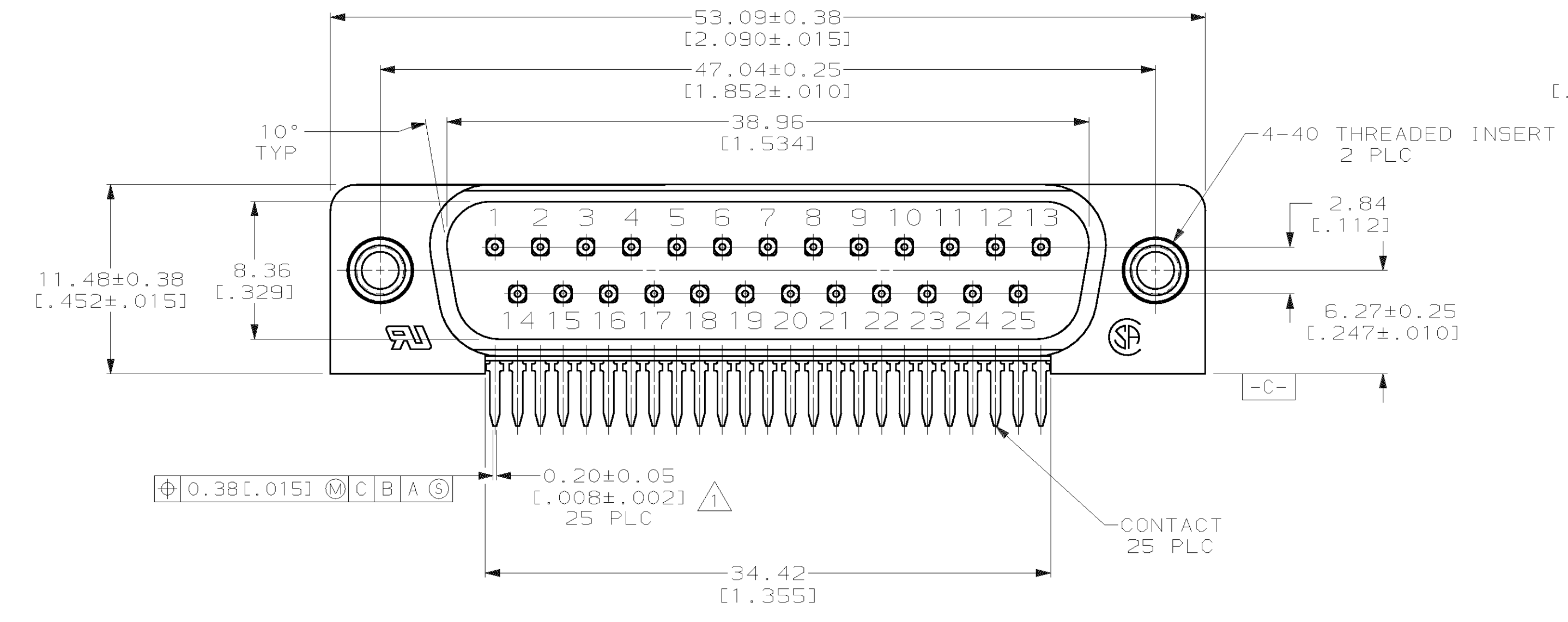
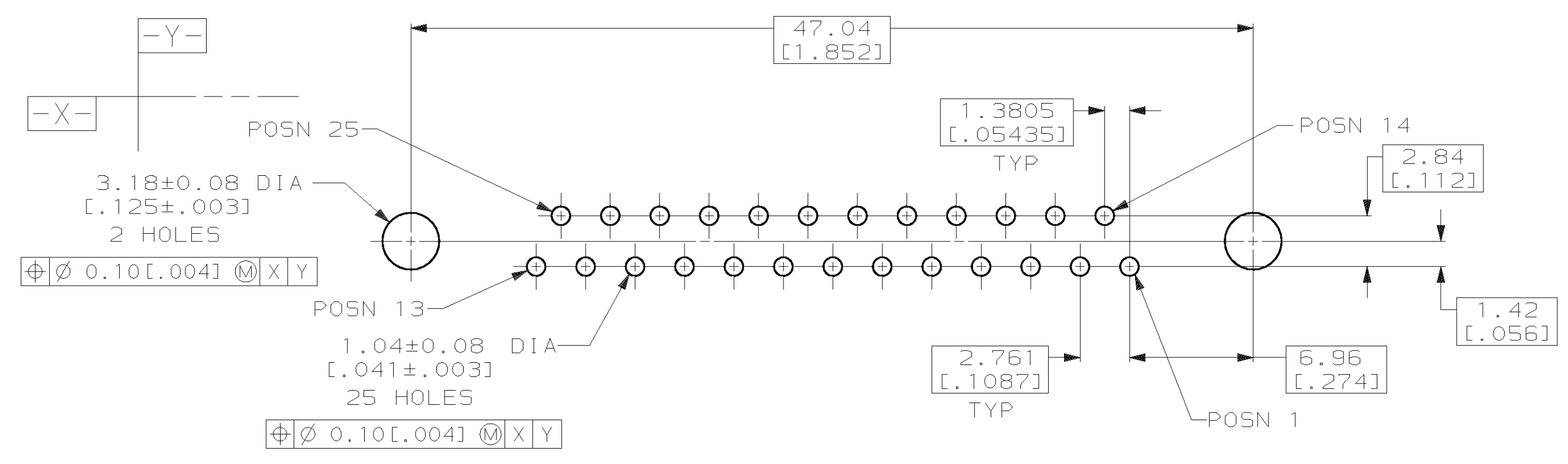
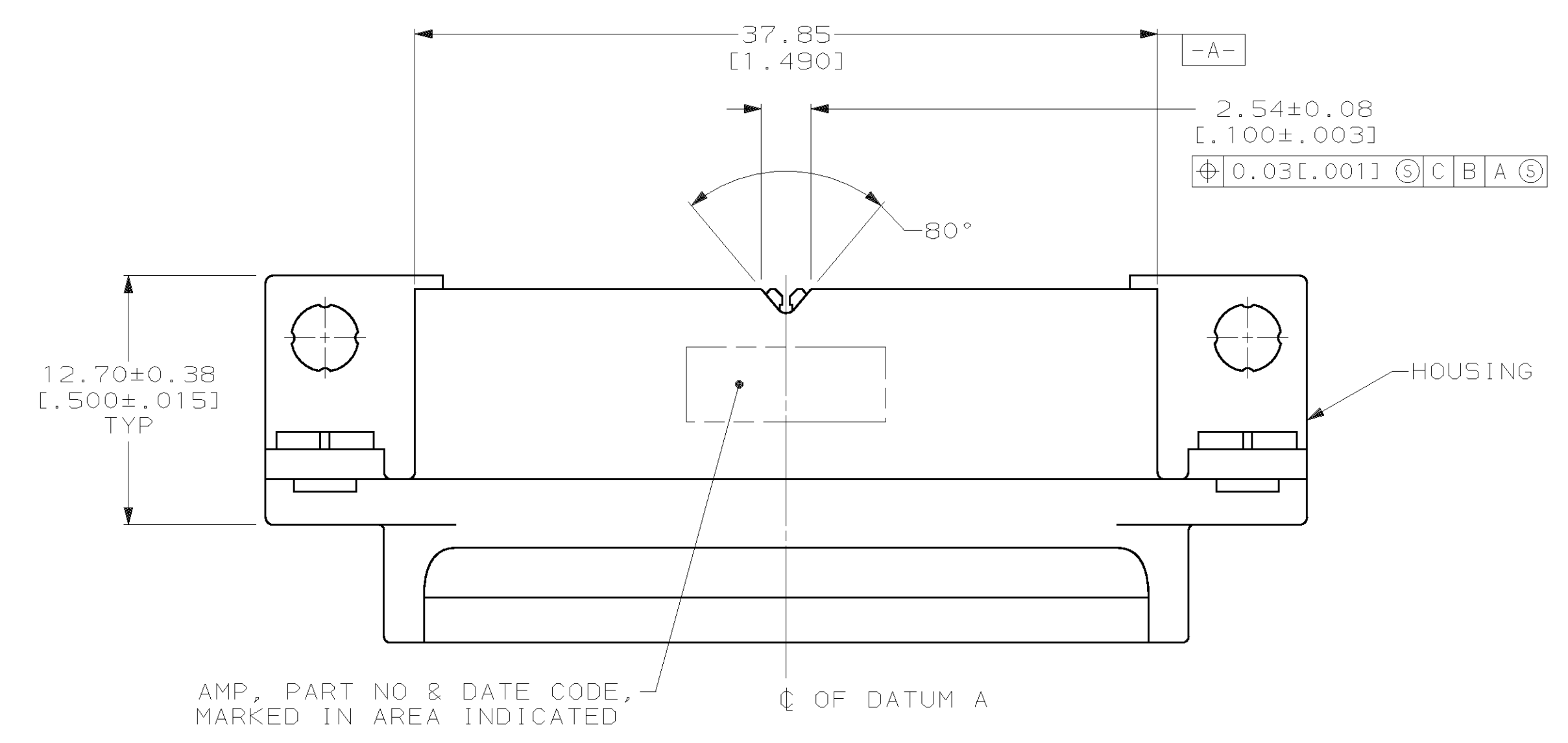

- ① POSITION TOLERANCE APPLIES AT TIP ONLY.
- ② NYLON OR POLYESTER, UL94V-0, BLACK.
- ③ BRASS PER MIL-C-50
- ④ GOLD PLATING PER MIL-G-45204, NICKEL PLATING PER QQ-N-290, TIN PLATING PER MIL-T-10727.
- ⑤ 0.76 μm [.000030] MIN GOLD FOR A LENGTH OF 3.81 [.150] MIN FROM MATING END, 3.05 μm [.000120] MIN TIN-LEAD FOR A LENGTH OF 3.68 [.145] MIN FROM OPPOSITE END, BOTH OVER 1.27 μm [.000050] MIN NICKEL.
- ⑥ GOLD FLASH FOR A LENGTH OF 3.81 [.150] MIN FROM MATING END, 3.05 μm [.000120] MIN TIN-LEAD FOR A LENGTH OF 3.68 [.145] MIN FROM OPPOSITE END, BOTH OVER 1.27 μm [.000050] MIN NICKEL.
- ⑦ GOLD PLATED FOR A LENGTH OF 3.81 [.150] MIN FROM MATING END, 0.25 μm [.000010] MIN GOLD IN MATED AREA. 3.05 μm [.000120] MIN TIN-LEAD FOR A LENGTH OF 3.68 [.145] MIN FROM OPPOSITE END, BOTH OVER 1.27 μm [.000050] MIN NICKEL.

	①	748865-3
	⑥	748865-2
	⑤	748865-1
	CONTACT FINISH	PART NO

DO NOT SCALE PRINT. UNLESS SPECIFIED DIMENSIONS IN mm [INCHES] TOLERANCES ON:	DR 08/03/89 S.WELDON	AMP INCORPORATED Harrisburg, Pa. 17105
2 PLC DEC ± 0.13 [.005]	CHK 8/29/89 R.STONE	
3 PLC DEC ± -	APPD 9/13/89 W.SWAIN	NAME
ANGLES ± 2°	APPD 9/13/89 C.RHODE	PLUG ASSEMBLY SIZE 3, 25 POSN, ALL PLASTIC, RIGHT ANGLE, .318 SERIES, AMPLIMITE® II
MATERIAL HOUSING: ② CONTACTS: ③ INSERTS: ZINC	PRODUCT SPEC 108-1226	SIZE
FINISH ④	APPLICATION SPEC 114-40027	D
CONTACTS: SEE TABLE	WEIGHT	CAGE CODE 00779
INSERTS: CLEAR CHROMATE		DRAWING NO. 748865
		SCALE 4:1

OBSELETE NOT THE LATEST REVISION